

RP-2001

RACK & PINION MATERIAL HOISTS

Most Versatile Platform Hoist

Standard Features

- » 2,000 lb Max Load Capacity*
- » 400 ft Max Vertical Travel**
- » 70 fpm Operating Speed*
- » 45"W x 70"L x 48"H Clear Platform
- » 100% Duty Cycle
- » 220V / 1P / 60Hz / 30A*
- » Base Unit Weight: 1,440 lbs
- » Steel Construction
- » 90 Degree Pivoting Platform
Allows for multiple load configuration
- » Soft-Start/Soft-Stop
Variable Frequency Drive for Smooth Acceleration and Deceleration
- » Fast Acting Overspeed Brake
- » Safety Chains on Access Sides
- » Drop-down Ramps on Access Sides
- » Extendable Pendant Control
- » Water Tight Connectors
- » 5'H Tower Sections (Stackable)
- » Anchors to Building or Scaffolding
Use standard anchorage brackets or custom made brackets every 10-15'
- » Material Use Only

Many Options Available

* Constant voltage is required to prevent damage and to maintain specified lift capacity and speed.

** Consult a structural engineer for heights over 200 ft or when unsure of required anchoring.

Material Use Only - No Riders



Shown without optional ANSI Platform Enclosure



For more information contact us at:

1-800-451-5053

Ph: 321-733-3387 Fx: 321-733-9433

360 East Drive, Melbourne, FL 32904, USA

sales@hi-techhoist.com www.hi-techhoist.com

RP-2001

RACK & PINION MATERIAL HOIST

Specifications subject to change without notification!

GENERAL DIMENSIONS

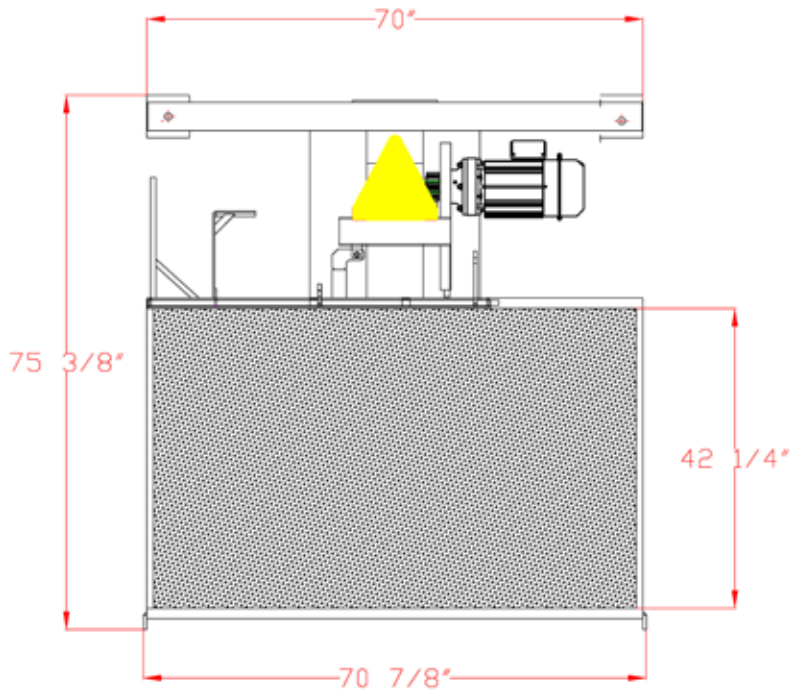

ANCHORAGE

DO NOT SUPPORT HOIST ON OUTRIGGER JACKS. THEY ARE FOR LEVELING DURING INSTALLATION ONLY.

THIS AREA MUST BE CAPABLE OF SUPPORTING TOTAL LOAD OF BASE, TOWER, PLATFORM AND LOAD. USE PLANKS OR CONCRETE SLAB TO PROVIDE ACCURATE BEARING STRENGTH.

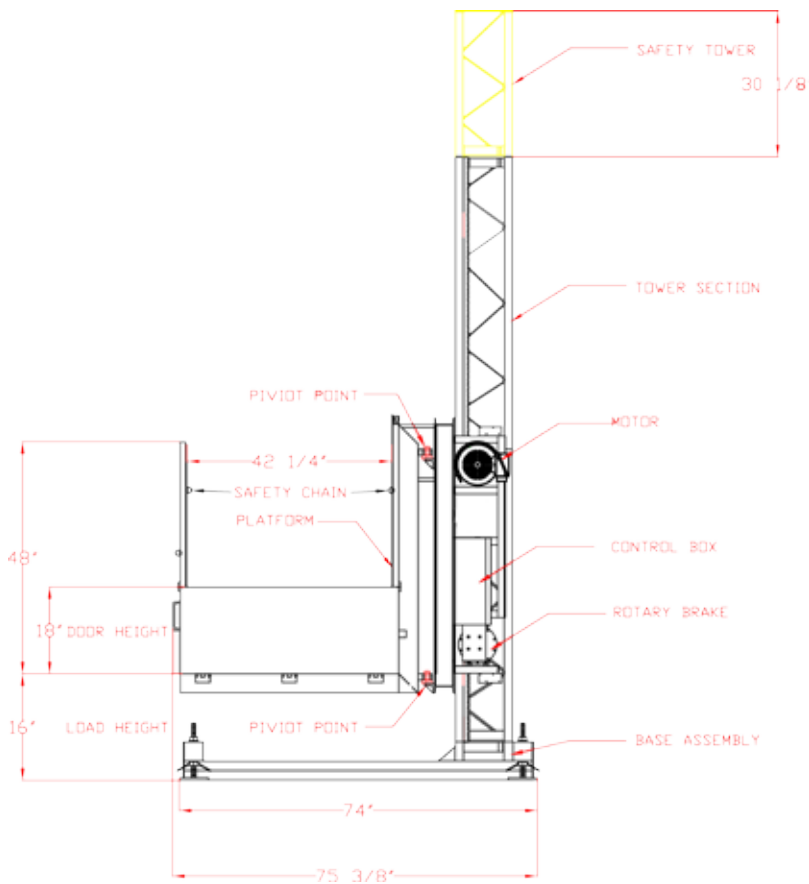
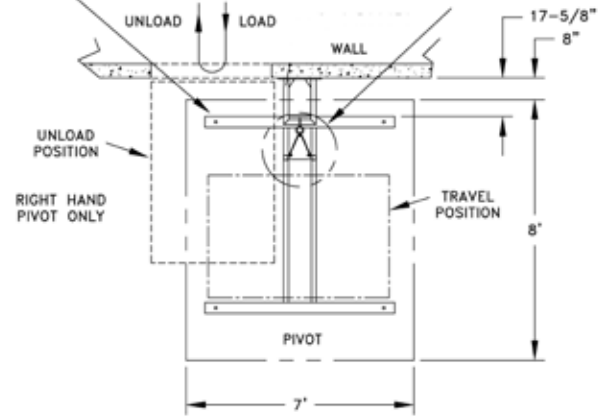

Anchor
10' - 15'

Anchor
10' - 15'

Anchor
10' - 15'

